

DEVELOPMENT OF A NEW FEMORAL IMPLANT FOR REVISION HIP ARTHROPLASTY

**Tim Rummens¹, Bert Croux¹, Quentin Goossens¹, Steven Leuridan¹,
Michiel Mulier², Jos Vander Sloten¹, Kathleen Denis¹, Leonard Pastrav¹**

¹*Department of Mechanical Engineering, KU Leuven, leonard.pastrav@kuleuven.be*

²*University Hospitals Leuven, KU Leuven*

Abstract: *The fixation of the cementless femoral implants used in revision total hip arthroplasty is mostly obtained in the distal part. Since in this region the medullar canal geometry is close to a circular cylinder, the implants should show some features in order to prevent rotation and subsidence under physiological loads. This paper proposes a new design for a modular femoral implant that includes a part with longitudinal splines and a threaded part. A finite element analysis estimates the stress in bone and relative micromotion.*

Keywords: *femoral implant, revision, total hip arthroplasty, modular, threaded implant*

1. Introduction

In orthopedics severely damaged joints are frequently replaced by prostheses and the success of such surgical procedure largely depends on the stability of the components (implants) inserted in bones. The fixation of an implant achieved intraoperatively is called primary fixation and, in uncemented hip replacement, it is usually realized by press fit. Afterwards, due to bone ingrowth and osseointegration process, a secondary fixation is obtained. A solid primary fixation is necessary for osseointegration to occur. It has been reported that the relative cyclic motion (micromotion) between bone and implant induced by the physiological loads should not exceed 150µm [Le Beguec, 2007].

Every year more than one million total hip arthroplasties (THA) are performed and, after several years, about 10% of them need revision. There are various reasons for revision surgery but the main reason is aseptic loosening. This is the case for 49% of all the revisions in the United Kingdom [MacInnes, 2012].

During the femoral revision procedure the unstable femoral implant is removed, the medullar canal is reamed and a new implant is inserted. In general, the fixation of revision

cementless femoral implants is realized in the distal part where the geometry of the medullar canal is close to a circular cylinder. In time, due to the physiological loads, a femoral implant could tilt, rotate, and subside in bone.

The current designs of revision implants can prevent tilting by increasing the stem length and rotation by using longitudinal splines, but subsidence is still a challenge [Tangsataporn, 2015]. To solve this issue a new design of a modular implant that includes a threaded part is proposed in this study.

2. Materials and Methods

2.1. Implant design

A common modular femoral prosthesis consists of a stem, neck and ball component. The prosthesis presented in this paper has five components interconnected by Morse tapers. as indicated in Figure 1. The novelty consists in the stem divided in three parts: the proximal component, the splined component, and the threaded component. The thread is intended to eliminate or at least reduce the subsidence.

A v-shaped thread with a single leaded pitch of 5 mm with a length of 25 mm is chosen to be a good compromise between insertion speed, stress distribution and pull out

performance. The thread depth is 1.5 mm while the minimum core diameter is 13 mm.

Figures 2, 3, and 4 show the internal structure of the proximal, splined, and threaded components, respectively.

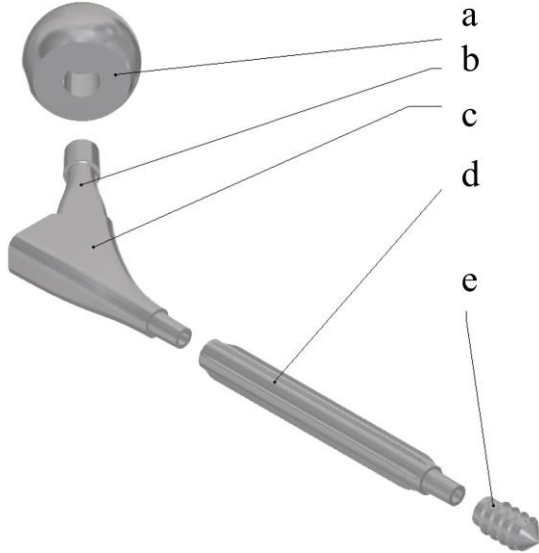

Figure 1: The proposed revision implant with (a) ball, (b) neck, (c) proximal component, (d) splined component, and (e) threaded component.

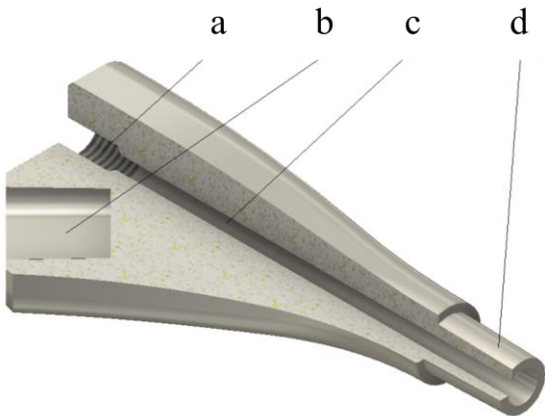

Figure 2: The proximal component with (a) internal thread for cover, (b) female part of the Morse taper connection between the proximal component and the neck component, (c) hole for assembly and disassembly purpose and (d) male part of the Morse taper connection between the proximal component and the splined component.

The longitudinal holes and other internal features are used in conjunction with assembling and disassembling tools during the insertion and removal processes. For example, Figure 5 shows an assembly tool connected to

the threaded part while Figure 6 illustrates the disassembling process.

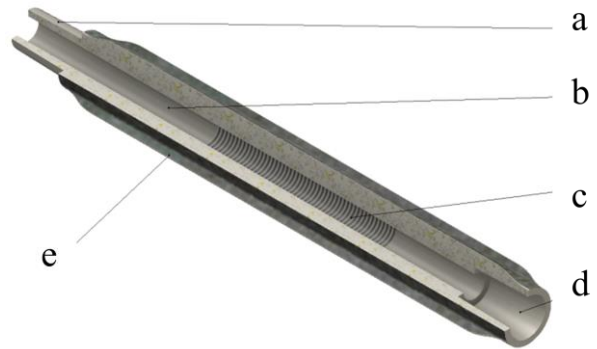

Figure 31: The splined component with (a) male part of the Morse taper connection between the splined component and the threaded component, (b) hole for assembly and disassembly purpose (c) internal thread used in disassembly process, (d) female part of the Morse taper connection between splined component and proximal component, and (e) splines

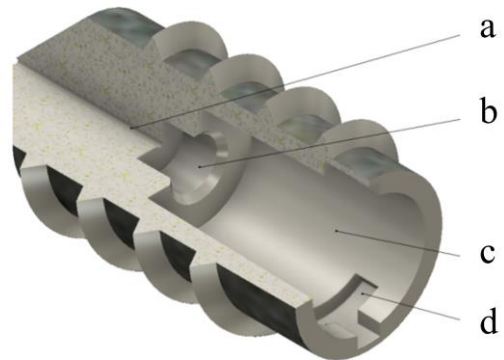

Figure 4: The threaded component with (a) pressure release hole with diameter 0.5 mm, (b) chamfered region used to support the end of the disassembly tool, (c) female part of the Morse taper connection with the splined component, and (d) T-slot feature.



Figure 52: The assembly tool inserted in the T-slot of the threaded component. In this way the threaded component is screwed and unscrewed in femur.



Figure 6: Illustration of the disassembling process.

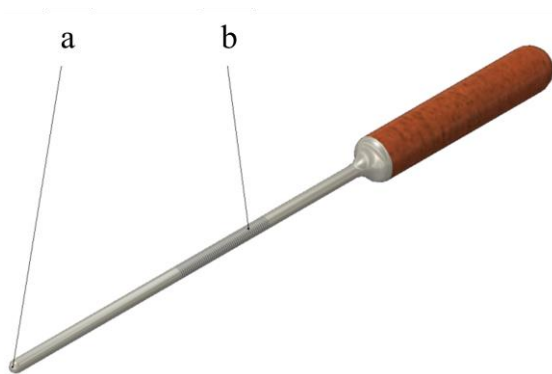

Figure 7: The disassembly tool with (a) spherical end and (b) external thread.

The prosthesis insertion process starts with the threaded component that is screwed inside the freshly reamed medullar canal (Figure 5). Afterwards the splined and proximal components are hammered inside the medullar canal until the Morse tapered surfaces are well connected. Finally, the corresponding neck and ball are attached.

During the prosthesis removal process the disassembly tool (Figure 7) is inserted in the longitudinal hole of the prosthesis and the tool external thread engages the internal thread of the splined component. The tool is screwed in until its spherical end touches the supporting chamfered surface inside the threaded component (Figure 4). Turning more after this moment results in pushing backwards the splined component until it is released from femur. Afterwards the threaded component is simply unscrewed with the same tool used during the insertion process (Figure 5).

2.2. Finite element analysis

Finite element analysis (FEA) was used to verify the stresses developed in femur under physiological load and to see if the proposed design was a plausible solution to subsidence.

The finite element model (FEM) of the prosthetic stem was based on a simplified geometry (Figure 8).

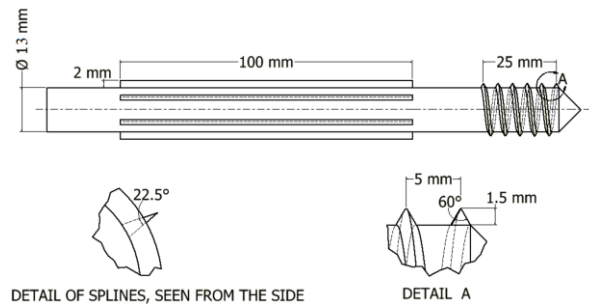

Figure 8: Simplified model geometry

A Standard Triangulation Language (STL) file containing the geometry of a femur was used to generate the corresponding FEM with different properties for the cortical and cancellous bone. To define the cancellous and cortical bone areas into the FEM solid mesh the Mimics software (Materialise, Leuven, Belgium) was used (Figure 9).

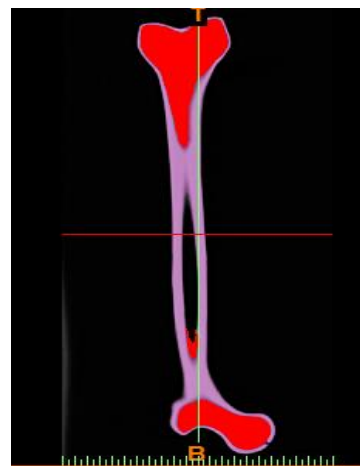

Figure 9: A mask of cortical (purple) and cancellous bone (red) in Mimics (Materialise, Leuven, Belgium).

Figure 10 shows the FEM of the stem inside the femur. Quadratic tetrahedral

elements with dimensions between 1 and 3 mm were used.

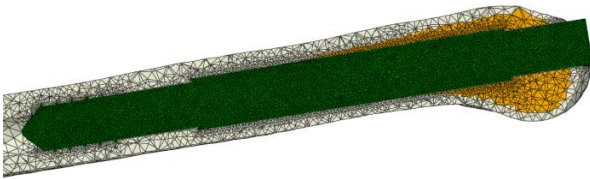

Figure 10: FEM of the implant inside the femur. The orange area is cancellous bone, the grey area is cortical bone and the implant is displayed in green.

Table 1 shows the material properties assigned to the stem while Table 2 shows the material properties for bone. The cancellous bone is considered isotropic material while the cortical bone is orthotropic.

Table 1: Material properties Ti-6Al-4V [CRP Meccanica]

Elastic modulus (GPa)	113.8
Poisson ratio	0.237

Table 2: Bone properties [Leuridan, 2017]

Cortical bone		
Elastic modulus (MPa)	11	9830
	22	9830
	33	14200
Poisson ratio	12	0.26
	23	0.1625
	32	0.26
Shear modulus (MPa)	12	3968
	23	3950
	32	3950
Cancellous bone		
Elastic modulus (MPa)		155
Poisson ratio		0.3

The FEM realized in Patran (MSC Software) was analyzed in Abaqus (Dassault Systèmes). A frictional behavior was created at the bone-implant interface, with a friction coefficient of 0.37 [Grant, 2007]. The numerical model of the femur-implant system was tested under an axial force equal to 2000 N and a torque equal to 24 Nm (Figure 11). These values correspond to a patient with a body mass weight equal to 80 kg [G. Bergmann, 1993, Costigan, 2002].



Figure 11: Prosthesis FEM and applied loads

3. Results

Figure 12 shows the von Mises stress in the threaded part. The grey areas represent stresses between 6 MPa and 26 MPa, which are still below the ultimate shear, compression and tension stress of cortical bone. Between the splines the stress ranges between 4 MPa and 6 MPa.

The relative bone-implant displacement was only 15 μm , value that should allow good osseointegration [Le Beguec, 2007].

The displacement under identical load was also calculated in a model of a currently used prosthesis, with only splines and no threaded component. In this case the highest relative displacement was 187 μm .

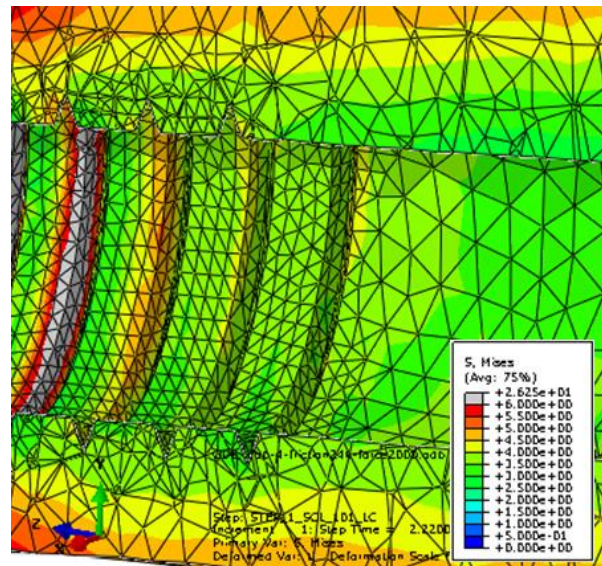

Figure 12: A close-up view of the von Mises stresses at the threaded component.

4. Conclusion

A modular prosthesis with a threaded tip and splined mid-stem has been designed and analyzed. The stress in the cortical bone due to

axial and torsional forces does not exceed the ultimate stress. Also the initial displacement is considerably less when using a threaded design (15 μm) in comparison to the same implant with only splines (187 μm). Further research including fatigue analysis is required to test this new implant in realistic conditions.

References

1. Bergmann, G., Graichen, F., & Rohlmann, A. Hip Joint Loading During Walking and Running, Measured in Two Patients, *Journal of Biomechanics* 1993 (26), 969–990.
2. Costigan, P. A., Deluzio, K. J., & Wyss, U. P. (2002). Knee and Hip Kinetics During Normal Stair Climbing, *Gait Posture* 2002 (16), 31–37.
- CRP Meccanica. Titanium Ti-6Al-4V Available from: <http://www.crpmeccanica.com/machining-titanium-ti-6al4v/>
3. Grant, J. A., Bishop, N. E., Götzen, N., Sprecher, C., Honl, M., & Morlock, M. M. (2007). Artificial Composite Bone as a Model of Human Trabecular Bone: The Implant-Bone Interface. *Journal of Biomechanics*. 2007, 40(5):1158-64.
4. Le Beguec, P., & Sieber, H.-P. *Revision of Loose Femoral Prostheses*. 2007.
5. Leuridan S., Goossens Q., Pastrav L., Roosen J., Mulier M., Denis K., Desmet W., Vander Sloten J. Determination of replicate composite bone material properties using modal analysis. *Journal of the Mechanical Behavior of Biomedical Materials*. 2017 Feb, 66:12-18.
6. MacInnes, S. J., Gordon, A., & Wilkinson, J. M. Risk Factors for Aseptic Loosening Following Total Hip Arthroplasty. In *Recent Advances in Arthroplasty*. 2012.
7. Tangsataporn, S., Safir, O. A., Vincent, A. D., Abdelbary, H., Gross, A. E., & Kuzyk, P. R. T. Risk Factors for Subsidence of a Modular Tapered Femoral Stem Used for Revision Total Hip Arthroplasty. *Journal of Arthroplasty*. 2015 (30), 1030–1034.