

DEVICES FOR INTERNAL CONICAL SURFACES MEASUREMENTS

Alexandru POTORAC¹, Dorel PRODAN², Florina CIORNEI³

^{1,2,3}Faculty of Mechanical Engineering, Mechatronics and Management, "Stefan cel Mare"
University of Suceava

¹alex@fim.usv.ro, ²prodan.d@fim.usv.ro, ³florina@fim.usv.ro

Abstract: The paper presents the fundamental theoretical background required in conical holes control. These notions are needed in designing and manufacturing devices for measuring internal conical surfaces. The principles to be considered are settled and the minimum notions required for the design of such devices are presented. The indirect control method of calibrated discs will be applied and universal mechanical or digital callipers and depth micrometer will be used in developing and designing the devices.

Keywords: device, taper, conical surfaces, measurement, calliper, micrometer

1. General aspects on designing and setting conical fittings' precision

Conical fittings are widely used in machine building due to the advantages offered (accurate centering, sealing possibility, gap adjustment option).

The most important elements of a conical fitting are presented in Figure 1, [1].

- o D_M, D_m - the large and small diameters, respectively, of conical hole;

- o d_M, d_m - the large and small diameters, respectively, of conical shaft;

- o $\alpha/2$ - angle between the generator and the axis;

- o α - cone angle, in axial section;

- o L_{23}, l_{23} - distance between two cross-sections of diameters D_2 (d_2) and D_3 (d_3), respectively;

- o L, l - distance between the reference surface for dimensioning and the nominal cross-section of diameter D_1 , or d_1 respectively - one of the frontal surfaces of the part or any other surface of functional significance can be chosen as reference surface;

- o L_B - basic distance of conical fitting, representing the distance, on axial direction,

between two surfaces of the assembly, L'_B , or directly connected to the assembly, L''_B ;

- o l_D, l_d - length of internal and external cone, respectively;

- o H - contact length between the two conical surfaces.

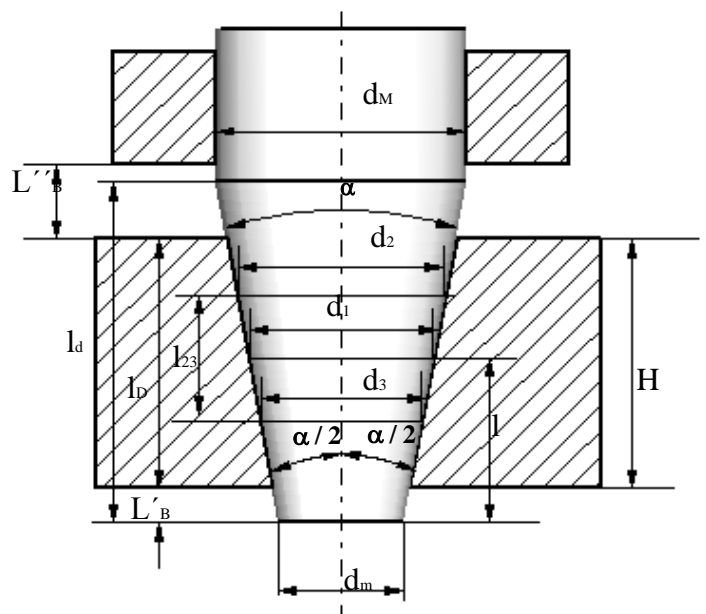

Figure 1. Conical fitting

The following relations are valid between the elements of a conical fitting:

- inclination:

$$I = \operatorname{tg} \frac{\alpha}{2} = \frac{D_2 - D_3}{2L_{23}} = \frac{d_2 - d_3}{2l_{23}}; \quad (1)$$

- conicity:

$$C = 2 \cdot I = 2 \cdot \operatorname{tg} \frac{\alpha}{2} = \frac{D_2 - D_3}{L_{23}} = \frac{d_2 - d_3}{l_{23}}. \quad (2)$$

There are two methods applied for prescribing the conical fitting precision: nominal conicity method and tolerated conicity method, respectively, with the known cases from literature.

2. Calibrated discs method

The principle and the device for calibrated discs method – used in the Tolerances and Dimensional Control Laboratory of Faculty of Mechanical Engineering, Mechatronics and Management are presented in Figure 2 and Figure 3, respectively, [2].

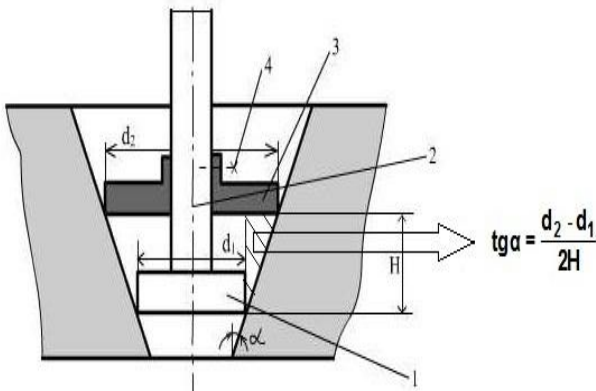

Figure 2. Internal conicity measuring principle using the calibrated discs method

From Figure 2, the “ $\operatorname{tg}(\alpha)$ ” parameter can be found, where the following notations are used:

- o d_1 – small disc diameter;
- o d_2 – large disc diameter;
- o H – the distance between the two discs measured using the depth calliper.

The devices are manufactured within different size ranges, depending of minimum and maximum diameters of measured cones.

The calibrated discs device, Figure 3, consists in two calibrated discs, the smaller one with the

diameter d_1 and the larger one with the diameter d_2 . The small disc is fitted on the rod, while the large disc glides along the rod. The relative position of the discs, in order to find the H dimension, can be fixed using a locking screw.

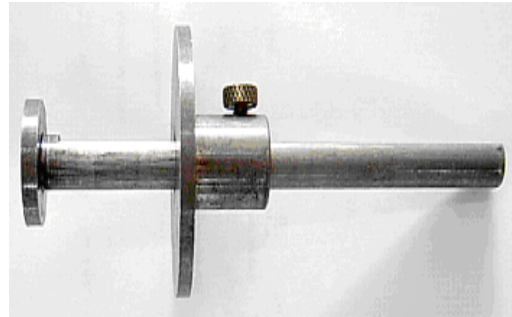

Figure 3. Internal conicity measurement device with calibrated discs

The above presented device has the subsequent disadvantages:

- low measurement productivity, as it involves supplementary operations for fixing the discs in place and measuring the H distance;
- low measurement precision.

Considering the mentioned weaknesses, the design and manufacturing of devices for internal conicity measurements using callipers (mechanical and digital) and depth micrometers (mechanical or, even digital) is required, [3], [4].

3. Vernier device for internal conicity measurements

The vernier device proposed for internal conicity measurements is presented in Figure 4, and has the following main parts:

- fixed calibrated disc;
- sliding calibrated disc;
- locking screws;
- universal mechanical calliper.

The measuring range is large due, both to the length of the ruler and to the possibility of using discs of different diameters; the measurement resolution is 0.05 mm for H dimension.



Figure 4. Vernier device for internal conicity measurement

4. Digital device for internal conicity measurements

The digital instrument used in internal conical surfaces measurements, presented in Figure 5, has the same main constitutive parts as the previous device, the difference being only the replacement of the mechanical calliper with a digital one.



Figure 5. Digital device for internal conicity measurements

The measurement range is large both by the instrumentality of the length of the ruler, as well as through the possibility of using discs of different diameters and the measurement resolution is 0.01 mm for H dimension.

5. Micrometric device for internal conicity measurements

The micrometric instrument designed for internal conicity measurements is presented in Figure 6. The merely distinction compared to the preceding devices consists in utilizing a depth micrometer for H dimension measurement.



Figure 6. Micrometric device for internal conicity measurements

The measuring range is restricted by the micrometer's race range, but the option of using discs of various diameters is still applicable and the measurement resolution is 0.01mm for H dimension.

6. Conclusions

- Surfaces and machine elements' conicity measurement is an important and essential operation and consequently, adequate measuring devices are required (large measurement range, increased precision).
- Measurement of internal conicity is more difficult as compared to the measurement of external conicities (there are more methods and instruments for external conicity measurements). Accordingly, an increased attention in manufacturing new instruments for internal conicity measurements is required.
- An indirect measurement method was used, namely the calibrated discs method;
- The measurement range has to be as large as possible and, to this end, series of discs pairs are provided, having the external diameters corresponding to the measured parts. To this purpose, the method allows, by using adequate pairs of discs, measurements of cones having the half-angle within the range of 0° and virtually 90° . For the devices made in the Tolerances and Dimensional Control Laboratory, the measuring range of the instruments is presented in Table 1.

Table 1. Measurement range

No.	Measuring device	Measurement range
1.	Vernier device	$3-60^\circ$
2.	Digital device	$5-70^\circ$
3.	Micrometric device	$20-60^\circ$

- The measurement precision and accuracy has to be as high as possible.
- To this end, the diameters of the discs were measured using the digital calliper which has a measurement resolution of 0.01 mm/division and a maximum error of 0.02 mm [5]. The distance H is found using the mechanical calliper (maximum error 0.05 mm), [5], digital calliper (maximum error 0.02 mm), [5], and depth mechanical micrometer (maximum error 0.02 mm), respectively. Taking into account these errors, that is, the measurement error of the calibrated discs' diameters, as well as the measurement error of the H dimension, the measurement error for the designed and manufactured devices is presented in Table 2.

Table 2. Measurement error

No.	Measuring device	Error
1.	Vernier device	$\pm 5'$
2.	Digital device	$\pm 4'$
3.	Micrometric device	$\pm 4'$

The values for estimated measurement errors from Table 2 were obtained for a 15 mm distance between the two cross-sections to be measured. The error decreases significantly for increased distance between cross-sections.

The plots from Figure 7 highlight a good agreement between the results obtained using the new devices while the old device indicates values smaller with a few minutes.

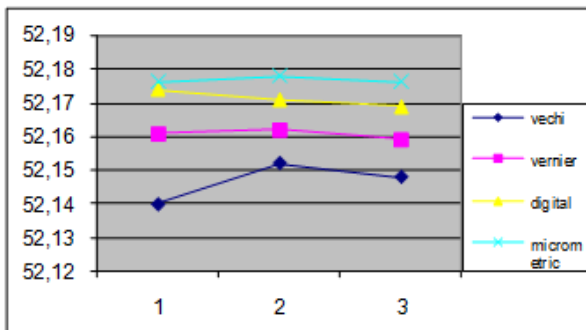
**Figure 7.** Comparison of results

The smallest values are indicated by the classical device, followed, in order, by the ones obtained with the vernier device, the digital device and the micrometric instrument.

On the whole, the results presented for validation in Fig.7 proved a good agreement, all together with increased precision, higher measurement productivity and economically competitive cost for the new designed, manufactured and developed devices.

References

- [1] LĂZĂRESCU, C., STETIU, C.E., - Toleranțe, ajustaje. Calculul cu toleranțe, Editura Tehnică București, 1984;
- [2] POTORAC, A., PRODAN, D., - Toleranțe și control dimensional, Îndrumar de laborator FIMMM, (in print), Universitatea „Ștefan cel Mare” Suceava;
- [3] RAȚĂ-MUNTEAN, V. - Dispozitive tehnologice: elemente de proiectare și construcție, Matrix Rom, București, 2011;
- [4] MILEA, A. - Informație și incertitudine în măsurări, Editura Tehnică, București, 1982;
- [5] <http://www.msi-viking.com/Mitutoyo>