

# EXPERIMENTAL RESEARCH ABOUT INFLUENCE OF INCLINATION ANGLE DIRECTION UPON THE SURFACE ROUGHNESS IN BALL END MILLING OF OLC45 (C45) MATERIAL

PAȘCA Ioan<sup>1</sup>, LOBONȚIU Mircea<sup>2</sup>

<sup>1</sup> *phd. student, North University of Baia Mare, Str. Dr. Victor Babes, nr.62 A , Baia Mare, Romania, e-mail: [pascaing@yahoo.com](mailto:pascaing@yahoo.com).*

<sup>2</sup> *phd. prof., North University of Baia Mare, Str. Dr. Victor Babes, nr.62 A , Baia Mare, Romania, e-mail: [mircea.lobontiu@ubm.ro](mailto:mircea.lobontiu@ubm.ro).*

**Abstract:** Machining with ball end mills become a very usefull process to obtain pieces with complex surfaces. Possibilities of machining with ball nose end mills represent a adequate process to achieve surfaces with a good quality. That fact lead to exclude some finishing operations that was necessary if the surfaces was machined with a different process and tools. Elimination of this finishing operation have a great economic advantages, because milling with ball nose end mills offer a adequate surface roughness and precision. But, all of this are possible only with a good choise of different values of cutting parameters and with an optimum inclination angle represented by value and direction of inclination. The present paper includes an experimental investigation of surface roughness depending on the value and direction of tool axis inclination in raport with surface machined.

**Keywords:** *roughness, surface, inclination angle, direction.*

## 1. Introduction

Obtaining a high quality of surfaces machined with ball end mills present a great interest for reserchers and persons involved in machining of die and mould surfaces. The surface quality in ball end milling is the results of influence of a number of factors such as: the stability of machine tools, the correct choosing of cutting tools and cutting parametters, properties of material machined and the tool angle inclination upon the surface normal. To have good results all these factors should be chosen to have a minimal negative influence in the process.

Machining of dies and moulds surfaces in milling process involved polishing operations that represent sometimes approximately two thirds of the total manufacturing costs [4]. In this way the milling process with ball nose end mills represent a solution to reduce the costs of process and of final product but only if the values of parameters involved in process are adequate. Chosen of optimum value of different parameters is difficult because it is necessary to reduce the time of machining and to obtain surfaces with good roughness. In international context a great number of researches is dedicated to surface quality

prediction. Some of them is dedicated to experimental research, but a lot of them are proposing some mathematical models. That mathematical models proposed take into account the cutting speed, feed value variation and the following parameters: cutting depth [8], cutting depth and radial depth [5], hardness of the material and tool radius [7].

By using a cutting tool angle between the axis of tool and machined surface can contribute to a higher quality of machined surface [1].

The paper [9] and [6] suggested that a tool inclination in the range of 10...20 degrees represents the optimum machining strategy for high speed milling in the die and mould making industry, but in other paper like [10] the optimal value of inclination angle in ball end milling of block materials was found at 15 degrees. Another reserch show that when piece was machined with inclination of tool axis of -17 degrees following Y axis in one way the profile of the machined work-piece, show the improvement of the machined surface texture quality [2]. In paper [3] it is noted that in practice the angle of 45 degrees for inclination of tool axis the quality of surface is low.

Because surface roughness have an important effect upon product quality and economicity of process, was necessary to study the influence of inclination direction of tool axis upon surface normal and try to compare the surface roughness obtained in some situation.

**2. The analysis of tool axis inclination**

Machine tools with five axis lead the possibility to work with one or two angle of tool axis inclination in relation with normal to the surface, situation that allow to achieve better cutting conditions and therefore a high quality machined surface. Working with this inclination angle the contact zone between tool edge and material is changing that involve another condition with modification of chip thickness and area of contact. Also, the cutting forces are different and the energy consumed are different. Using this inclination angle we have possibility to reduce the costs of process and to obtain a higher quality.

Inclination angle can be applied to tool around the axis X,Y or Z corresponding to the structural characteristics of machine tools and to characteristics of surfaced machined.

Inclination angles proposed for analysis in this paper are around the X axis by angle A positive (Fig.1) or negative (Fig.2) and around to Y axis by angle B positive (Fig.3) or negative (Fig.4).

**3. Effects of inclination angle upon effective cutting speed**

By using an inclination angle between tool axis and normal to surface we change some characteristics of process. One of them is effective cutting speed thus value depending by effective diameters. In order, the effective diameters depend by cutting depth, radial depth and inclination angle. Increasing of effective diameters involve the increase of effective cutting speed.

To establish the value of effective speed milling  $V_{c-eff}$  corresponding to inclination of 15 degrees angle value, we used relation (1) [3]:

$$V_{c-eff} = \frac{\pi \cdot n \cdot D \sin \left[ \theta_n + \arccos \left( \frac{R - a_p}{R} \right) \right]}{1000} \quad (1)$$

with the following condition:

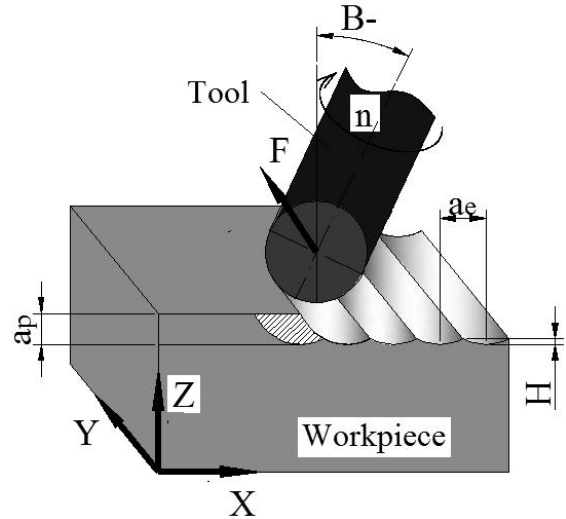

Figure 1: Inclination of tool axis in B negative direction around Y axis

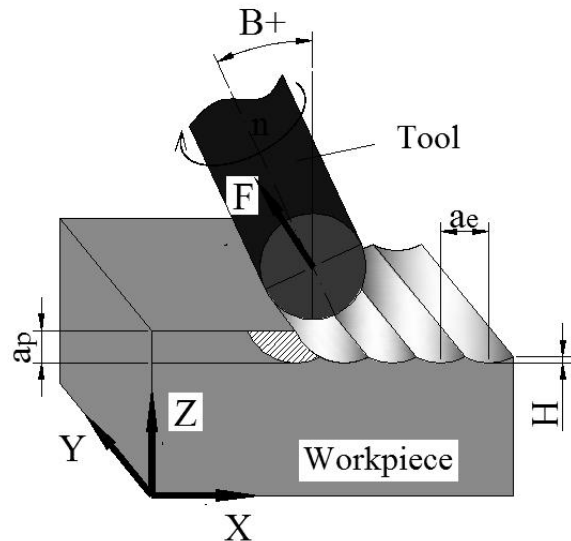

Figure 2: Inclination of tool axis in B positive direction around Y axis

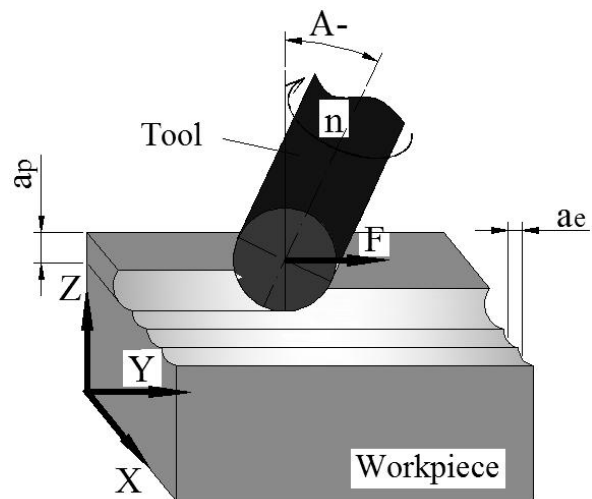
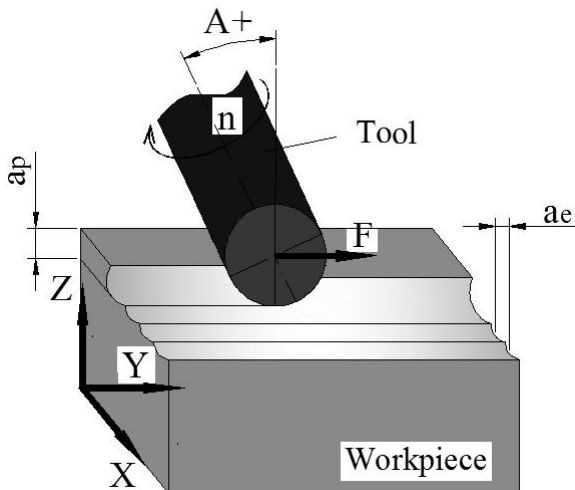

Figure 3: Inclination of tool axis in A negative direction around X axis



**Figure 4:** Inclination of tool axis in A positive direction around X axis

$$\arcsin\left(\frac{ae}{2R}\right) \langle \theta_n \leq 90 - \arccos\left(\frac{R - ap}{R}\right), \quad (2)$$

where:

- D – nominal diameter of tool [mm];
- ap – cutting depth [mm];
- n – spindle speed [rot/min];
- θn – inclination of tool axis [grade];
- R – tool radius [mm].

Geometrical parameters values used in our experiments are presented in Table 1.

**Table 1:** Geometric parameters used

No.	Geometric elements	Units of measurement	Values
1	Diameter of ball end mill	mm	16
2	Cutting depth	mm	0,2
3	Axial depth	mm	0,2
4	Feed per tooth	mm	0,1
5	Tool angle inclination	degrees	15

The results obtained for two values of spindle speed used in our experiments are presented in Table 2.

#### 4. Experimental work and conditions

Machining by using a cutting tool angle between the axis and machined surface can contribute to a higher quality of machined surface

[1]. Analyzing the indication presented in paper [9],[6],[10], [11] and [2] about optimum value of inclination angle we choose to apply in our experiment value of 15 degrees in raport with normal to the surface.

**Table 2:** Effective cutting speed values

No.	Speendle speed n [rot/min]	Inclination angle [degrees]	Effective cutting speed [m/min]
1	10000	15	234,6
2	15000		352

Once identified the optimum value of inclination angle we found that is necessary to extend the studies by analysing the influence of inclination angle direction upon surface roughness. We want to establish the best direction of inclination angle that lead to high quality of machined surface, but according with some defaults machining conditions.

#### 4.1 Experimental setup

To make the experimental analysis of inclination angle direction upon surface roughness was necessary a number of experiment that was made by using a OKUMA MU400VA five-axis CNC milling machine equipped with a maximum spindle speed of 15,000 rpm (Fig.5.), that was propriety of S.C. RAMIRA S.A. We used a tool holder SRM2160SNM and inserts SRG16C-VP15TF made by Mitsubishi Carbide that is presented in Fig.6.



**Figure 5:** Five-axis milling machine



Figure 6: Tool holder SRM2160SNM

#### 4.2 Workpiece configuration

The material used was OLC-45 (C45) with the following characteristics: 0,42...0,50% C, 0,50...0,80% Mn, 0,17...0,37% Si, maximum 0,040% P etc. The workpiece had a economic shape because we can machined six surfaces with the same quaty of material (Fig.7.)

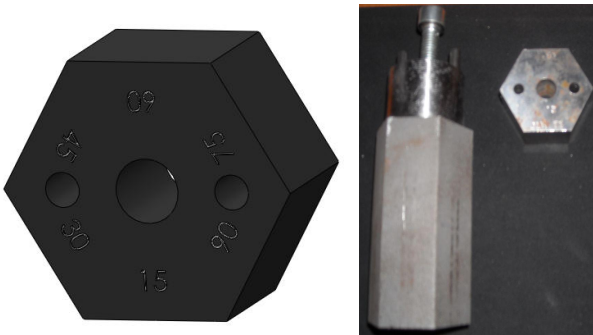

Figure 7: Workpiece configuration

#### 4.3 Surface roughness measurements

In the technical literature and industry are many parameters used to defined the surface roughness, but in generally is defined as the inherent irregularities of the workpiece affected by machining process. The paper [3] show that the most popular of the 2D parameters is the average roughness Ra. In order to obtain more information about surface machined we made the measurements of surface roughness in feed direction and perpendicular to it. We used the tester TR200 that we applied on new device that provides the conditions of perpendicularity and parallelism between roughness tester feeler and feed direction. That measurements stand is presented in Fig. 8.

#### 4.4 Experimental conditions

In order to establish the conditions utilized in our experiments we must say that all experiments were conducted using in feed milling direction and with parameters indicated in Table 1, 2 and 3.



Figure 8: Roughness tester TR200 with adaptor device

Table 3: Experimental conditions

Nr	Inclination angle [degrees]	Spindle speed [rot/min]	Inclination direction
1	15	10000	A0B+15
2			A0B-15
3			A+15B0
4			A-15B0
5		15000	A0B+15
6			A0B-15
7			A+15B0
8			A-15B0

#### 5. Experimental results and discussion

Experimental data on surface quality of the measurements obtained were analyzed in feed direction and perpendicular to feed direction for two values of effective cutting speed and were centralized in Table 4.

Table 4: Experimental data

Nr.	Direction of inclination	Effective cutting speed [m/min]	Surface roughness [ $\mu\text{m}$ ]	
			In feed direction	Cross to feed direction
1	A0B+15	234,6	0,176	0,317
2		352	0,191	0,341
3	A0B-15	234,6	0,189	0,435
4		352	0,195	0,498
5	A+15B0	234,6	0,335	0,357
6		352	0,367	0,491
7	A-15B0	234,6	0,317	0,360
8		352	0,192	0,411

Direction of inclination angle of tool axis relative to the surface normal is important because significant differences can arise in terms of quality. Both, absolute value of the angle of inclination and direction of this angle are very important.

Variation of surface roughness when machined OLC 45 at 15 degrees inclination angle value applied in different direction is presented in Fig. 9 for measurements made in feed direction, and in Fig.10. for measurements made perpendicular to feed direction.

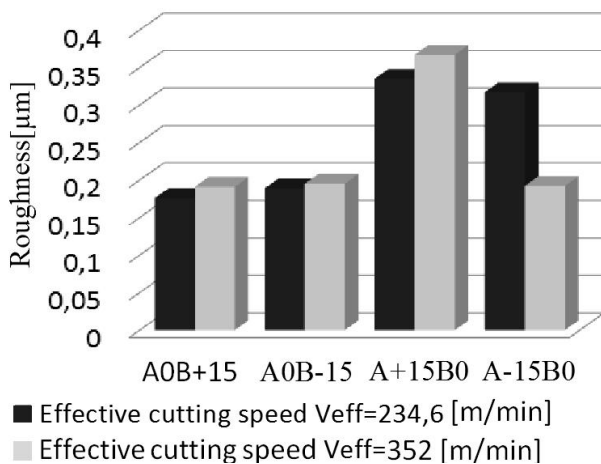

**Figure 9:** Variation of roughness for measurements made in feed direction

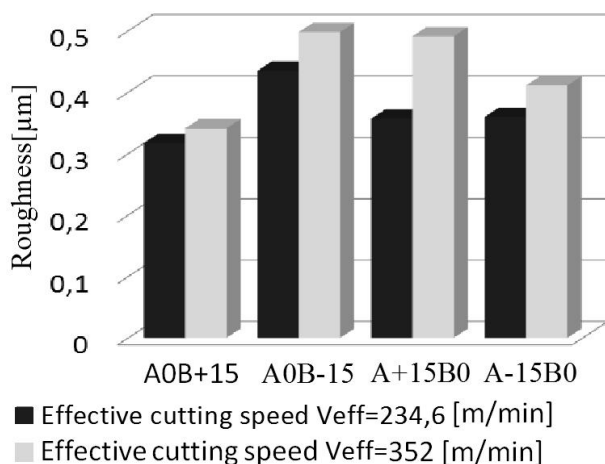

**Figure 10:** Variation of roughness for measurements made perpendicular to feed direction

The results reveal the fact that it is recommended to avoid situation of inclination when results contact between material machined and tool edge were the effective cutting speed is reduce. This situation appear when we inclined tool axis around X axis in direction A positive and around Y axis in direction B negative. In this case when inclination angle value is 15 degrees it is

recommended to not increase the cutting speed because the surface roughness is worse, fact observed for situation when we made measurements in feed direction and perpendicular to feed direction. It is possible that for another value of inclination angle the surface roughness variation to be different.

## 6. Conclusions

Experimental results show that direction of inclination in ball end milling process have a great influence upon surface roughness.

Using the direction of inclination angle around the X axis with angle A positive or negative must be avoid because the surface roughness is weaker comparativ with direction in inclination made around Y axis. Best results of surface roughness is obtained when we incline tool axis around Y axis with angle B positive. Difference between surface roughness obtained with inclination angle in B positive direction, whose the best situation, and inclination in A positive direction is about 90% for measurements made in feed direction and 40% for measurements made perpendicular to feed direction.

## References

- [1] Antoniadis, A., Bilalis, N., Savakis, C., Maravelakis, E. and Petropoulos, G., *Influence of machining inclination angle on surface quality in ball end milling*, Proceedings of AMPT2003, Dublin, Ireland, 8-11 July 2003.
- [2] Boujelbene, M., Moisan, A., Bouzid, W. and Torbaty, S., Variation cutting speed on the five axis milling, *Journal of Achievements in Materials and Manufacturing Engineering*, Vol. 21, Issue 2, April 2007.
- [3] Daymi, A., Boujelbene, M., Linares, M., Bayraktar, E. and Ben Amara, A., *Influence of workpiece inclination angle on the surface roughness in ball end milling of the titanium alloy Ti-6Al-4V*, *Journal of Achievements in Materials and Manufacturing Engineering*, Vol.35, Issue 1, July 2009.
- [4] Fallbohmer, P., Rodriguez, C., A., Ozel, T. and Altan, T., *High-speed machining of cast iron and alloy steels for die and mould manufacturing*, *Journal of Materials Processing Technology* 98, pp. 104-115, 2000.
- [5] Kadirgama, K., Noor, M., Rahman, M., Rejab, R., Haron, C. and Abou-El-Hossein, K., Surface roughness prediction model of 6061-

- T6 Aluminium alloy machining using statistical method, *European Journal of Scientific Research*, Vol.25, No. 2, ISSN 1450-216X, 2009.
- [6] Ko, T., J., Kim, H., S. and Lee, S., S., *Selection of the machining inclination angle in high-speed ball end milling*, *International Journal of Advanced Manufacturing Technology* 17, pp. 163-170, 2001.
- [7] Krizbergs, J. and Kromanis, A., *Methods for prediction of the surface roughness 3D parameters according to technological parameters*, 5<sup>th</sup> International DAAM Baltic Conference „Industrial engineering-adding innovation capacity of labour force and entrepreneurs”, Tallinn, Estonia, 20-22 April 2006.
- [8] Rashid, M., Gan, S. and Muhamad, N., *Mathematical modeling to predict surface roughness in CNC milling*, *World Academy of Science, Engineering and Technology* 53, 2009.
- [9] Schultz, H. and Hock, S., *High-speed milling of dies and moulds-cutting conditions and technology*, *Annals of the CIRP* 44, pp. 35-38, 1995.
- [10] Tonshoff, H., K., and Hernandez, J., C., *Die manufacturing by 5 and 3 axes milling*, *Journal of Materials Processing Technology* 20, pp. 105-119, 1989.
- [11] Vidakis, N., Antoniadis, A., Savakis, C. and Gotsis, P., *Simulation of ball end tools milling*, *Proceedings of International Conference ICPR 2001*, Prague, Czech Republic, 29.07-03.08.2001.